

- NOTE: 1. ALL OEM RESPONSIBLE WIRING SHOWN BELOW IS "TYPICAL"  
PLEASE CONSULT SPECIFIC APPLICATION
2. RED INDICATES POWER SUPPLIED BY THE ECM
  3. BLUE INDICATES POWER AND SIGNALS INTO THE ECM
  4. BLACK INDICATES RETURNS TO THE ECM AND GENERIC OEM WIRING
  5. GREEN INDICATES DATA LINK

OEM RESPONSIBILITY

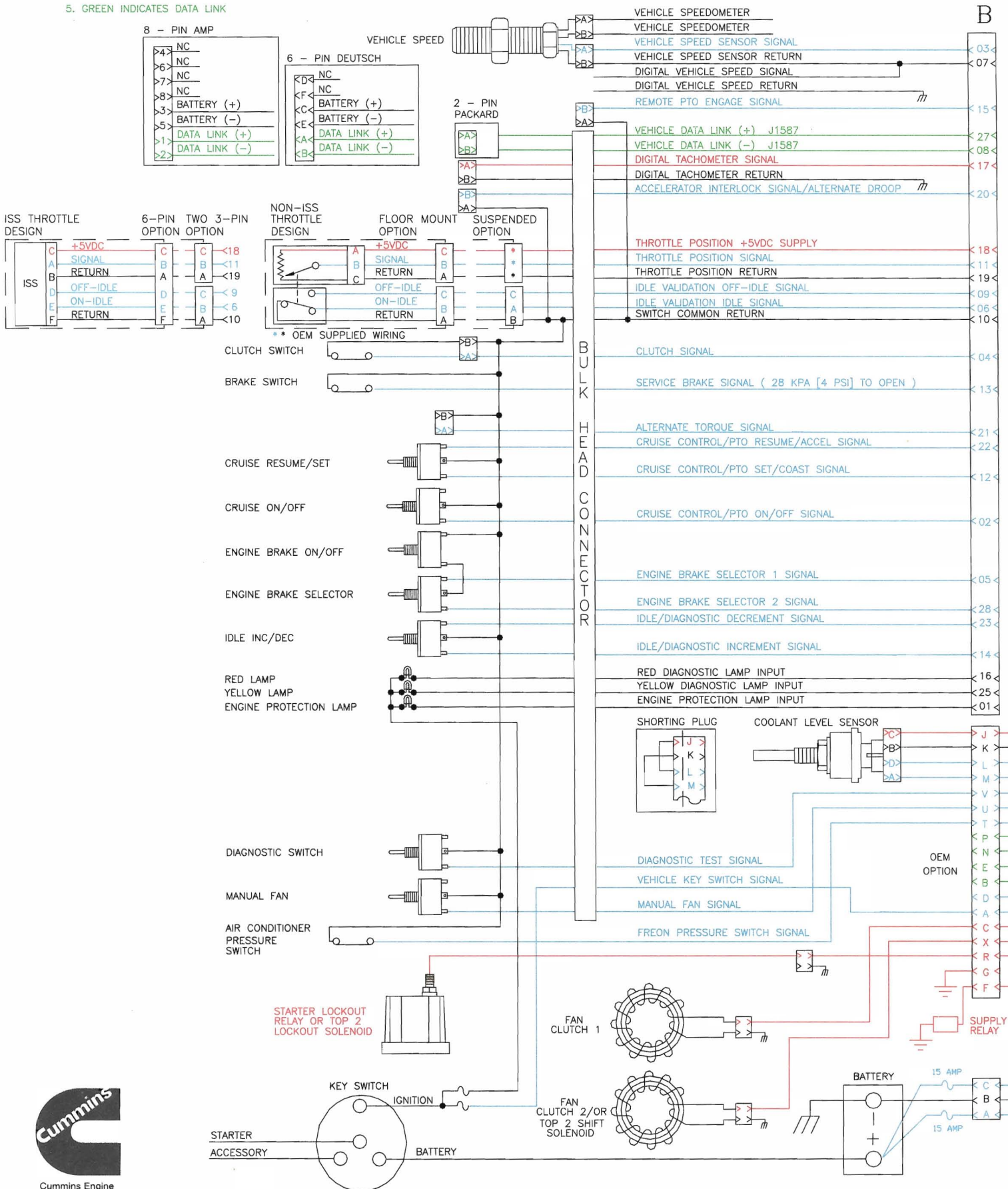

Cummins Engine Company, Inc.

# CELECT™ Plus WIRING DIAGRAM

(for ECM Part NO. 3096662) 1/14/99

BULLETIN NO. 3666146-04

OEM RESPONSIBILITY

CUMMINS RESPONSIBILITY 

ENGINE HARNESS M11 PART NO. 3096694  
ENGINE HARNESS N14 PART NO. 3609966

WIRE NUMBERS  
M-11 N-14

A

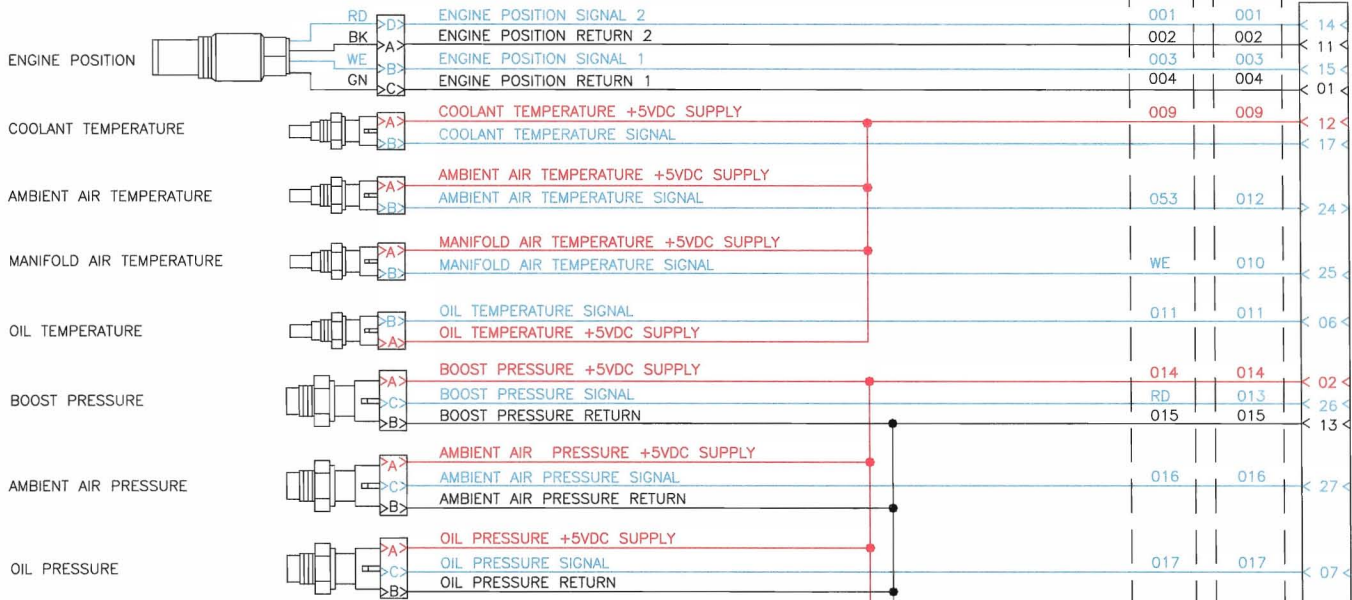

SENSOR CONNECTOR A

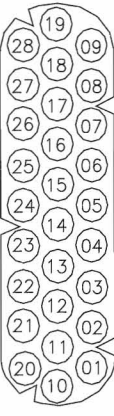

OEM CONNECTOR B

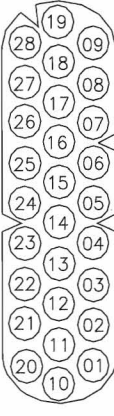

ACTUATOR CONNECTOR C

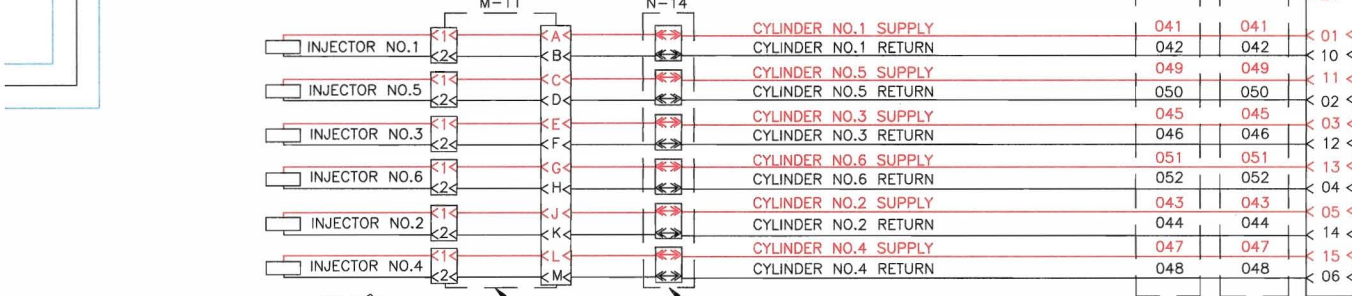
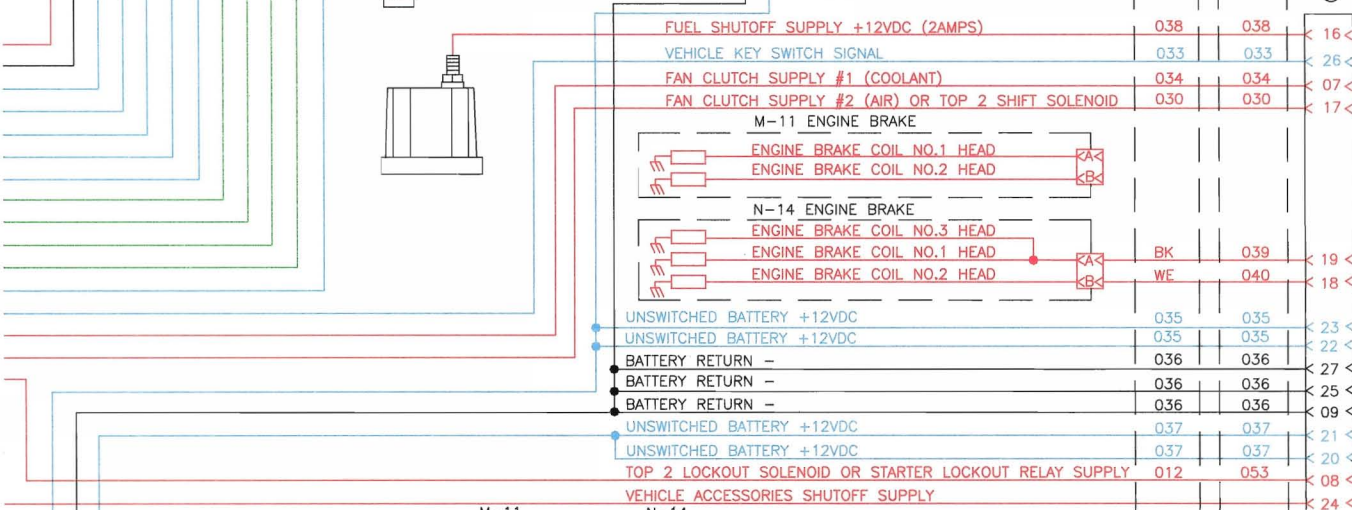
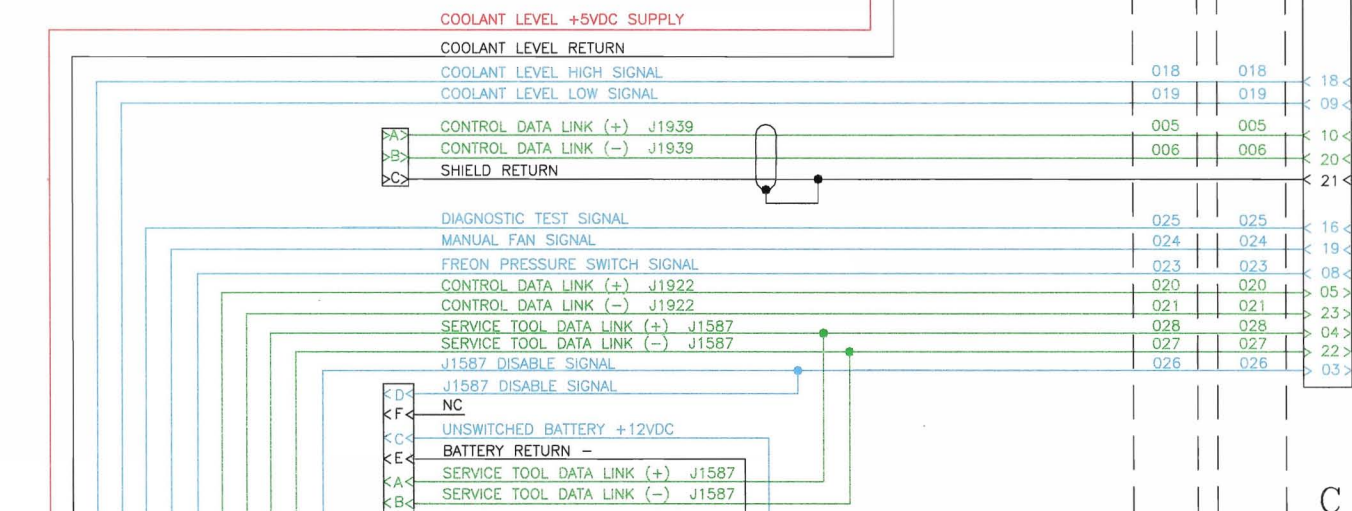
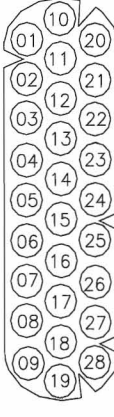

CUMMINS RESPONSIBILITY 

ROCKER BOX PASS THROUGH

## ▲ WARNING ▲

This diagram is provided as a diagnostic tool for trained, experienced technicians only. Improper troubleshooting or repair can result in severe personal injury or death or property damage. See important instructions in Service Manual.

### ELECTRICAL SPECIFICATIONS

#### DATA LINK (Vehicle and Control)

- Positive wire to chassis ground
  - 2.5 to 5.0 volts
- Negative wire to chassis ground
  - 0.0 to 2.5 volts

#### ALL CONTINUITY CHECKS

- OK (no open circuit) if less than 10 Ω

#### ALL SHORTS TO GROUND

- All circuits
  - OK (no short circuit) if more than 100 kΩ

#### 5 V POWER SUPPLY (Sensor Only)

- @ ECM/Harness
  - 4.75 to 5.25 volts

#### SOLENOIDS

- Fuel Shutoff Valve
  - Coil Resistance = 7 to 8 ohms
- Injectors
  - 0.5 to 1.5 ohms after subtracting the multimeter resistance.

#### ECM CONNECTOR

Retaining Cap Screw Torque = 2 N•m [18in-lb]

#### INJECTOR

Pigtail Retaining Nut Torque = 1.6 N•m [14 in-lb]

#### SHORT CIRCUIT TO EXTERNAL VOLTAGE

- OK if less than 1.5 volts

### SENSOR SPECIFICATIONS

#### OIL PRESSURE SENSOR

Torque (threaded style) = 14 N•m [10 ft-lb]

Pressure (kPa)	Pressure [psi]	Voltage (volts)
0	0	0.40 to 0.60
172.37	25	1.40 to 1.60
344.74	50	2.40 to 2.60
517.11	75	3.40 to 3.60
689.48	100	4.40 to 4.60

#### BOOST PRESSURE SENSOR

Torque (threaded style) = 14 N•m [10 ft-lb]

Pressure (mmHg)	Pressure [inHg]	Voltage (volts)
0	0	0.42 to 0.58
646.48	25.45	1.42 to 1.58
1292.88	50.90	2.42 to 2.58
1939.36	76.35	3.42 to 3.58
2585.76	101.80	4.42 to 4.58

#### AMBIENT AIR PRESSURE SENSOR

Torque (capscrew) = 9 N•m [80 in-lb]

Altitude (m)	Altitude [ft]	Voltage (volts)
0 (sea level)	0	4.00 to 4.58
915	3000	3.60 to 4.40
1829	6000	3.20 to 4.00
2744	9000	3.00 to 3.80
3659	12000	2.60 to 3.40

Voltage Output (± 60mV) = (Ambient Pressure [inHg] X 4.0V) ÷ 30.54 [inHg] + 0.5V

#### ALL TEMPERATURE SENSORS

Torque = 14 N•m [10 ft-lb]

Temperature (°C)	Temperature [°F]	Resistance (Ω)
0	32	30k to 36k
25	77	9k to 11k
50	122	3k to 4k
75	167	1350 to 1500
100	212	600 to 675

#### VEHICLE SPEED SENSOR

- Torque = 47 N•m [35 ft-lb]
- First Coil Resistance = 750 to 1100 Ω
- Second Coil Resistance = 1100 to 1500 Ω

#### ENGINE POSITION SENSOR

- Torque = 20 N•m [15 ft-lb]
- First Coil Resistance = 1000 to 2000 Ω
- Second Coil Resistance = 1000 to 2000 Ω

#### ACCELERATOR PEDAL (IVS, ISS, & APS)

- Idle Validation Circuit Resistance:
  - For ON and OFF-IDLE states
  - IVS, ISS - MAX Closed Circuit Resistance < 125 Ω
  - IVS, ISS - MIN Open Circuit Resistance > 100 kΩ
- Accelerator Position Sensor Coil Resistance:
  - Between supply and return wires
    - 2000 to 3000 ohms
  - Between supply and signal wires (released pedal)
    - 1500 to 3000 ohms
  - Between supply and signal wires (depressed pedal)
    - 200 to 1500 ohms

**NOTE:** Released resistance minus depressed resistance **must** be 1000 ohms.

## CELECT™ PLUS FAULT CODE INFORMATION

**LEGEND:** \* = Applies to 98N14 and 98M11 calibrations only

FAULT CODE LAMP	PID(P) SID(S) FMI	REASON	EFFECT (Only when fault code is Active)
111 Red	S254 12	Error internal to the ECM related to memory hardware failures or internal microprocessor communication failures.	Engine might die. Possible no start.
115 Red	P190 2	No engine speed signal detected at both pairs of signal pins 1 and 15 and pins 11 and 14 of sensor harness connector.	Engine will die and <b>not</b> restart.
121 Yellow	S021 10	No engine speed signal detected at one pair of pins, either pins 1 and 15 or pins 11 and 14 of sensor harness connector.	None on performance.
122 Yellow	P102 3	High voltage detected at boost pressure sensor signal pin 26 of sensor harness connector.	Derate in power output of the engine.
123 Yellow	P102 4	Low voltage detected at boost pressure sensor signal pin 26 of sensor harness connector.	Derate in power output of the engine.
131 Red	P091 3	High voltage detected at accelerator position signal pin 11 of the OEM harness connector.	Severe derate (power and speed).
132 Red	P091 4	Low voltage detected at accelerator position signal pin 11 of the OEM harness connector.	Severe derate (power and speed).
135 Yellow	P100 3	High voltage detected at oil pressure signal pin 7 of sensor harness connector.	No engine protection for oil pressure.
141 Yellow	P100 4	Low voltage detected at oil pressure signal pin 7 of sensor harness connector.	No engine protection for oil pressure.
143 Engine protection Yellow *	P100 1	Low oil pressure detected. Voltage at oil pressure signal pin 7 of the sensor harness connector indicates oil pressure lower than 55 kPa [8 psi] at idle to 800 rpm; 55 to 173 kPa [8 to 25 psi] at 800 to 1200 rpm; 173 to 208 kPa [25 to 30 psi] at 1200 to 2400 rpm for M11; 138 to 208 kPa [20 to 30 psi] at 1200 to 2400 rpm for N14.	Progressive power and speed derate with increasing time after alert. If engine protection shutdown is enabled, engine will shut down 30 seconds after the Engine Protection Lamp or the Red lamp* starts flashing.
144 Yellow	P110 3	High voltage detected at coolant temperature signal pin 17 of sensor harness connector.	Possible white smoke. Fan will stay ON if controlled by the ECM. No engine protection for coolant temperature.
145 Yellow	P110 4	Low voltage detected at coolant temperature signal pin 17 of sensor harness connector.	Possible white smoke. Fan will stay ON if controlled by the ECM. No engine protection for coolant temperature.
151 Engine protection Yellow *	P110 0	Voltage at coolant temperature signal pin 17 of the sensor harness connector indicates coolant temperature above 104°C [220°F].	Progressive power and speed derate with increasing time after alert. If engine protection shutdown is enabled, engine will shut down 30 seconds after the Engine Protection Lamp or the Red lamp* starts flashing.
153 Yellow	P105 3	High voltage detected at intake manifold temperature signal pin 25 of sensor harness connector.	Possible white smoke. Fan will stay ON if controlled by the ECM. No engine protection for intake manifold temperature.
154 Yellow	P105 4	Low voltage detected at intake manifold temperature signal pin 25 of sensor harness connector.	Possible white smoke. Fan will stay ON if controlled by the ECM. No engine protection for intake manifold temperature.
155 Engine protection Yellow *	P105 0	Voltage at intake manifold temperature signal pin 25 of the sensor harness connector indicates intake manifold temperature above 93.3°C [200°F].	Progressive power and speed derate with increasing time after alert. If engine protection shutdown is enabled, engine will shut down 30 seconds after the Engine Protection Lamp or the Red lamp* starts flashing.
212 Yellow	P175 3	High voltage detected at oil temperature signal pin 6 of sensor harness connector.	No engine protection for oil temperature.
213 Yellow	P175 4	Low voltage detected at oil temperature signal pin 6 of sensor harness connector.	No engine protection for oil temperature.
214 Engine protection Yellow *	P175 0	Voltage at oil temperature signal pin 6 of the sensor harness connector indicates oil temperature above 123.9°C [255°F].	Progressive power and speed derate with increasing time after alert. If engine protection shutdown is enabled, engine will shut down 30 seconds after the Engine Protection Lamp or the Red lamp* starts flashing.
221 Yellow	P108 3	High voltage detected at ambient air pressure signal pin 27 of sensor harness connector.	Power derate by 15%.
222 Yellow	P108 4	Low voltage detected at ambient air pressure signal pin 27 of sensor harness connector.	Power derate by 15%.
234 Red	P190 0	Engine speed signal on pins 1 and 15 and/or pins 11 and 14 of sensor harness connector indicates engine speed greater than 2630 rpm.	Fuel shutoff valve closed until engine speed falls to 2000 rpm.

FAULT CODE LAMP	PID(P) SID(S) FMI	REASON	EFFECT (Only when fault code is Active)
235 Engine protection Yellow *	P111 1	Voltage on the coolant level low signal pin 9 of sensor harness connector indicates low radiator coolant level.	Progressive power and speed derate with increasing time after alert. If engine protection shutdown is enabled, engine will shut down 30 seconds after the Engine Protection Lamp or the Red lamp* starts flashing.
241 Yellow	P084 2	Lost vehicle speed signal on pins 3 and 7 or pin 7 of OEM harness connector and engine block ground.	Engine speed limited to max. vehicle speed without vehicle speed sensor parameter value. Cruise control, progressive shift, gear down protection, and road speed governor will <b>not</b> work.
242 Yellow	P084 12	Invalid or inappropriate vehicle speed signal detected on pins 3 and 7 or pin 7 of the OEM harness connector and engine block ground. Signal indicates an intermittent connection or possible tampering.	Engine speed limited to max. vehicle speed without vehicle speed sensor parameter value until key switch is OFF for 5 seconds.
243 Yellow	P121 4	Less than 6 volts detected at one of the engine brake driver pins 18 or 19 of actuator harness connector. Indicates a current draw from the ECM greater than 2 amps or faulty ECM power supply.	The engine brake can <b>not</b> be activated.
245 Yellow	S033 4	Less than 6 volts detected at fan clutch supply pins 7 and 17 of actuator harness connector. Indicates a current draw from the ECM greater than 2 amps or faulty ECM power supply.	The fan may <b>not</b> engage. Possible engine overheat, if an ECM controlled fan is in use.
249 Yellow	P171 3	High voltage detected at the ambient air temperature signal pin 24 of the sensor harness.	The idle shutdown ambient air temperature override feature will use the intake manifold temperature sensor value to determine idle shutdown and availability of override. No effect on engine performance.
254 Red	S017 4	Low voltage detected at fuel shutoff driver pin 16 of actuator harness connector. Indicates a current draw from the ECM greater than 2 amps or faulty ECM power supply.	The ECM turns off fuel shutoff valve supply voltage. The engine dies.
255 Yellow	S026 3	Externally supplied voltage detected at one of the following driver pins; Fuel shutoff valve pin 16, fan clutch pins 7 or 17, or engine brake pins 18 or 19 of actuator harness connector.	Fuel shutoff valve will <b>not</b> close ... OR ... fan will run all the time ... OR ... engine brake will activate.
256 Yellow	P171 4	Low voltage detected at the ambient air temperature signal pin 24 of the sensor harness.	The idle shutdown ambient air temperature override feature will use the intake manifold temperature sensor value to determine idle shutdown and availability of override. No effect on engine performance.
267 Yellow	P171 2	Voltage signal at the ambient air temperature sensor signal pin 24 of the sensor harness indicates the ambient air temperature above 54.4°C [130°F].	The idle shutdown ambient air temperature override feature will use the intake manifold temperature sensor value to determine idle shutdown and availability of override. No effect on engine performance.
269 Red	S152 14	Engine rpm detected when vehicle antitheft is active.	Engine will not start.
289 Yellow	S040 11	Externally supplied voltage detected going into the ECM vehicle accessory shutoff supply pin 24 in the actuator harness ... OR ... the ECM has failed.	The vehicle accessory shutdown will not function properly. No effect on engine performance.
311 Yellow	S001 6	Current detected at No. 1 injector return pin 10 of actuator harness connector when voltage supply pin 1 of actuator harness connector is OFF.	Speed derate to 1400 to 1600 rpm. Current to injector is shut off.
312 Yellow	S005 6	Current detected at No. 5 injector return pin 2 of actuator harness connector when voltage supply pin 11 of actuator harness connector is OFF.	Speed derate to 1400 to 1600 rpm. Current to injector is shut off.
313 Yellow	S003 6	Current detected at No. 3 injector return pin 12 of actuator harness connector when voltage supply pin 3 of actuator harness connector is OFF.	Speed derate to 1400 to 1600 rpm. Current to injector is shut off.
314 Yellow	S006 6	Current detected at No. 6 injector return pin 4 of actuator harness connector when voltage supply pin 13 of actuator harness connector is OFF.	Speed derate to 1400 to 1600 rpm. Current to injector is shut off.
315 Yellow	S002 6	Current detected at No. 2 injector return pin 14 of actuator harness connector when voltage supply pin 5 of actuator harness connector is OFF.	Speed derate to 1400 to 1600 rpm. Current to injector is shut off.
321 Yellow	S004 6	Current detected at No. 4 injector return pin 6 of actuator harness connector when voltage supply pin 15 of actuator harness connector is OFF.	Speed derate to 1400 to 1600 rpm. Current to injector is shut off.
322 Yellow	S001 5	No current detected at No. 1 injector return pin 10 of actuator harness connector when voltage supply pin 1 of actuator harness connector is ON.	Speed derate to 1400 to 1600 rpm. Current to injector is shut off.
323 Yellow	S005 5	No current detected at No. 5 injector return pin 2 of actuator harness connector when voltage supply pin 11 of actuator harness connector is ON.	Speed derate to 1400 to 1600 rpm. Current to injector is shut off.
324 Yellow	S003 5	No current detected at No. 3 injector return pin 12 of actuator harness connector when voltage supply pin 3 of actuator harness connector is ON.	Speed derate to 1400 to 1600 rpm. Current to injector is shut off.

FAULT CODE LAMP	PID(P) SID(S) FMI	REASON	EFFECT (Only when fault code is Active)
325 Yellow	S006 5	No current detected at No. 6 injector return pin 4 of actuator harness connector when voltage supply pin 13 of actuator harness connector is ON.	Speed derate to 1400 to 1600 rpm. Current to injector is shut off.
331 Yellow	S002 5	No current detected at No. 2 injector return pin 14 of actuator harness connector when voltage supply pin 5 of actuator harness connector is ON.	Speed derate to 1400 to 1600 rpm. Current to injector is shut off.
332 Yellow	S004 5	No current detected at No. 4 injector return pin 6 of actuator harness connector when voltage supply pin 15 of actuator harness connector is ON.	Speed derate to 1400 to 1600 rpm. Current to injector is shut off.
343 Yellow	S254 12	Communication error with the FPC OR engine position sensor cam sync error.	Possible none on performance. Possible engine may die or stumble.
352 Yellow	S232 4	Low voltage detected at sensor supply pins 2 and 12 of sensor harness connector. Indicates a current draw from the ECM greater than 0.3 amps or faulty ECM power supply.	Engine derates to no air fueling and simultaneous logging of Fault Codes 123, 141, 145, 154, 213, 222, and 422.
415 Engine protection Red *	P100 1	Voltage signal at oil pressure signal pin 7 of sensor harness connector indicates oil pressure lower than 55 kPa [8 psi] at idle to 800 rpm; 55 to 172 kPa [8 to 25 psi] at 800 to 2400 rpm.	Progressive power and speed derate with increasing time after alert. If engine protection shutdown is enabled, engine will shut down 30 seconds after the Engine Protection Lamp or the Red lamp* starts flashing.
422 Yellow	P111 2	Voltage detected simultaneously on both the coolant level high and low signal pins 9 and 18 of sensor harness connector ... OR ... no voltage detected on both pins.	No engine protection for coolant level.
431 Yellow	P091 3	Voltage detected simultaneously on both the idle validation off-idle and on-idle signal pins 6 and 9 of OEM harness connector.	None on performance.
432 Red	P091 13	No voltage detected at idle validation on-idle signal pin 6 of OEM harness connector when voltage at accelerator position signal pin 11 of OEM harness connector indicates pedal is <b>not</b> at idle ... OR ... no voltage detected at idle validation off-idle signal pin 9 of OEM harness connector when voltage at accelerator position signal pin 11 of OEM harness connector indicate pedal is at rest.	Engine will only idle.
433 Yellow	P102 2	Voltage signal at boost pressure signal pin 26 of sensor harness connector indicates high boost pressure but other engine characteristics indicate boost pressure must be low.	Derate to no-air setting.
434 Yellow	S251 4	Battery voltage at pin 20, 21, 22, and 23 of actuator harness connector (relative to return pins 9, 25, and 27 of actuator harness connector) fell below 6.2 volts for a fraction of a second ... OR ... ECM was <b>not</b> allowed to power down correctly (retain battery supply voltage for 3 seconds after key OFF).	Possible no noticeable performance effects ... OR ... possibility of engine dying ... OR ... difficulty in starting engine.
441 Yellow	P168 1	Battery voltage below normal operating level.	Possible no noticeable performance effects ... OR ... possibility of rough idle.
442 Yellow	P168 0	Battery voltage above normal operating level.	None on performance.
474 Yellow	S052 2	Either low voltage detected when 12 volts are commanded or voltage detected when no voltage is commanded.	Either the engine will <b>not</b> have starter lockout protection or the engine will not start.
536 Yellow	S040 11	Either low voltage detected when 12 volts are commanded or voltage detected when no voltage is commanded.	Top2 lockout solenoid will <b>not</b> function properly. Transmission will not shift properly.
537 Yellow	S051 11	Either low voltage detected when 12 volts are commanded or voltage detected when no voltage is commanded.	Top2 shift solenoid will <b>not</b> function properly. Transmission will not shift properly.
544 Yellow	S191 7	Autoshift failure; missed three shift attempts.	Top2 transmission will <b>not</b> be controlled correctly. Transmission remains in manual mode.
551 Red	P091 4	No voltage detected simultaneously on both the idle validation off-idle and on-idle signal pins 6 and 9 of OEM harness connector.	Engine will only idle.

Bulletin No. 3666146-04

To repair CELECT™ Plus engine harness, use Wiring Repair Kit, Part No. 3822926, which is a collection of connectors, seals, wires, test leads, tools, and miscellaneous accessories. To order, contact your local Cummins Authorized Distributor.

NOTE: 1. ALL OEM RESPONSIBLE WIRING SHOWN BELOW IS "TYPICAL"  
PLEASE CONSULT SPECIFIC APPLICATION

OEM RESPONSIBILITY

- 2. RED INDICATES POWER SUPPLIED BY THE ECM (AND BATTERY +12VDC INPUT)
- 3. BLUE INDICATES SIGNALS INTO THE ECM
- 4. BLACK INDICATES SIGNAL RETURNS TO THE ECM AND GENERIC OEM WIRING
- 5. GREEN INDICATES OTHER

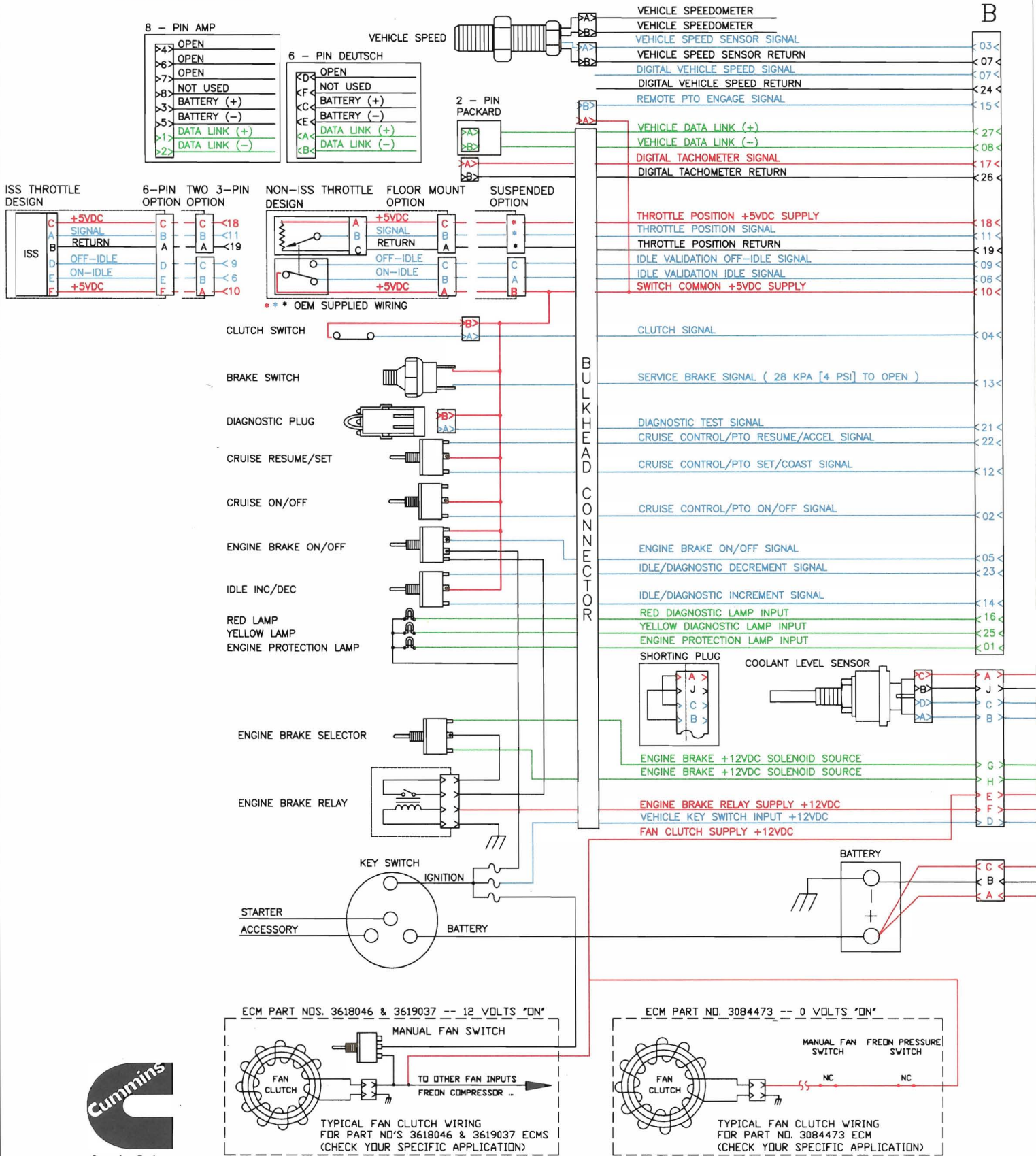

# CELECT™ WIRING DIAGRAM

(for ECM Part NO'S 3618046, 3619037, and 3084473)

OEM RESPONSIBILITY

CUMMINS RESPONSIBILITY 

SENSOR HARNESS L10 PART NO. 3073926  
 SENSOR HARNESS L10 PART NO. 3073930 (WITH AMBIENT AIR PRESSURE SENSOR)  
 SENSOR HARNESS M11 PART NO. 3083781  
 SENSOR HARNESS N14 WITH FLANGE-MOUNT PRESSURE SENSOR PART NO. 3618304  
 SENSOR HARNESS N14 WITH THREADED PRESSURE SENSOR PART NO. 3076354  
 SENSOR HARNESS 94 N14 WITH THREADED PRESSURE SENSOR PART NO. 3083770

WIRE NUMBERS

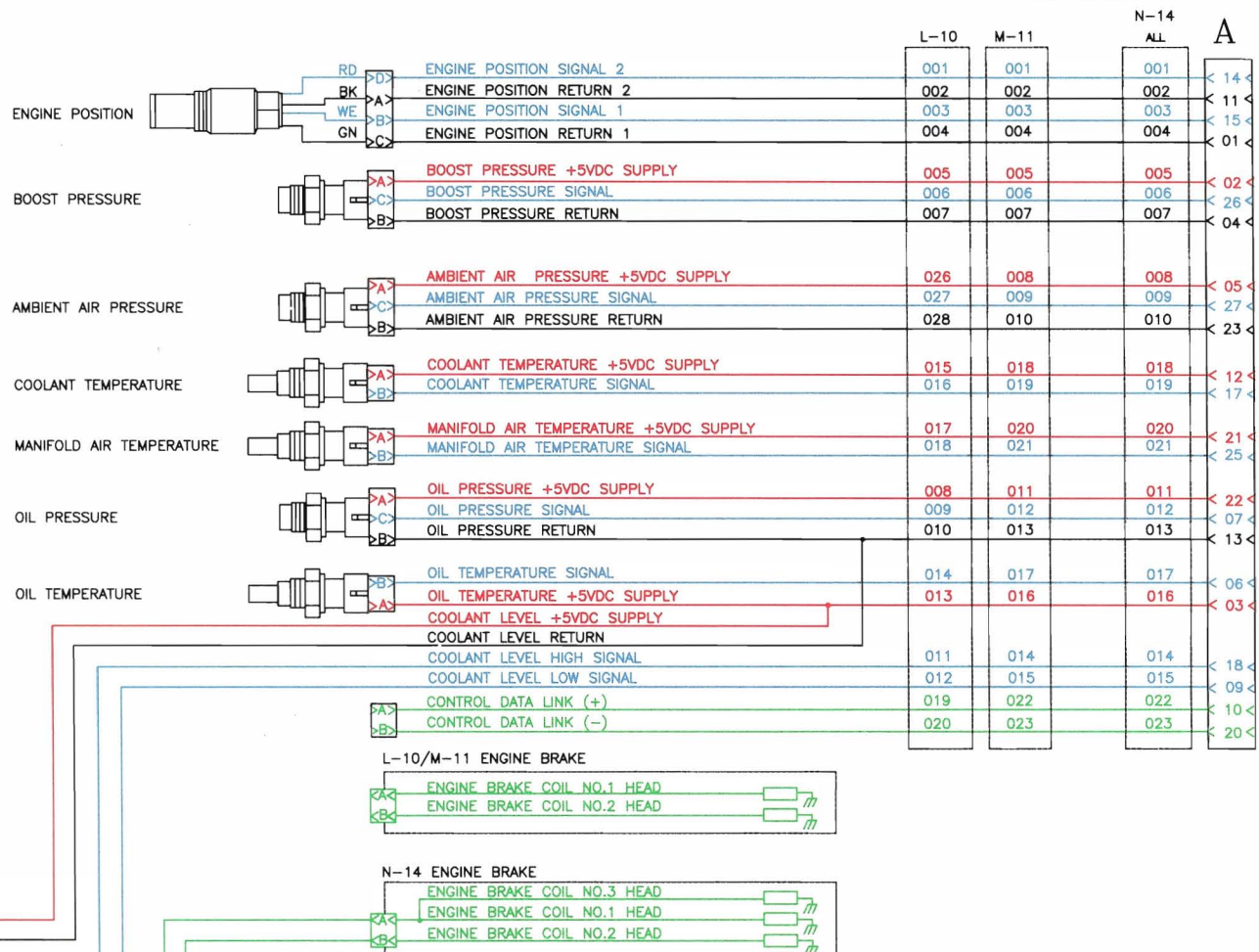

SENSOR CONNECTOR A

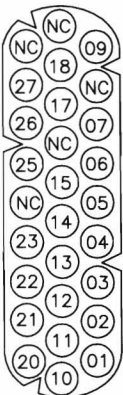

OEM CONNECTOR B

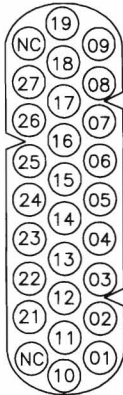

ACTUATOR HARNESS L10 PART NO. 3073927 ACTUATOR HARNESS M11 PART NO. 3083779  
 ACTUATOR HARNESS N14 WITH FLANGE-MOUNT PRESSURE SENSOR PART NO. 3618300\*  
 ACTUATOR HARNESS N14 WITH THREADED PRESSURE SENSOR PART NO. 3076352\*  
 \*THESE TWO CAN BE INTERCHANGED IF NECESSARY

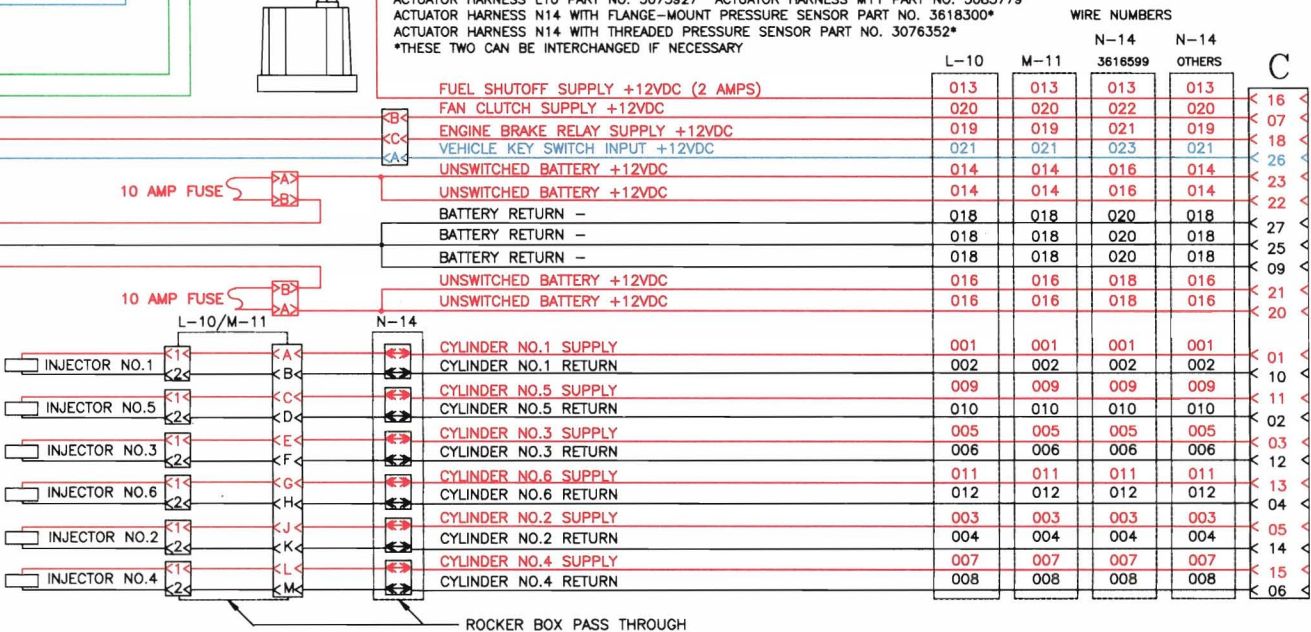

ACTUATOR CONNECTOR C

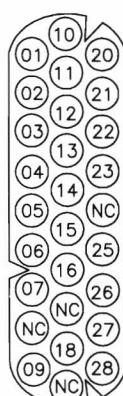

CUMMINS RESPONSIBILITY 



## ELECTRICAL SPECIFICATIONS

### DATA LINK (Vehicle and Control)

- Positive Wire to chassis ground
- 4.0 to 5.0 VDC
- Negative Wire to chassis ground
- 0.0 to 1.0 VDC

### ALL SHORTS TO GROUND

- EPS and VSS circuits
- O.K. (no short circuit) if > 10 Mohms
- ALL OTHERS
- O.K. (no short circuit) if >100 Kohms

### ALL CONTINUITY CHECKS

- O.K. (no open circuit) if < 10 Ohms

### SHORT CIRCUIT TO EXTERNAL VOLTAGE

- O.K. if < 1.5 VDC

### 5 V POWER SUPPLY (Sensor and Switch)

	@ ECM	@ Harness
Sensor	4.75 to 5.25 VDC	4.75 to 5.25 VDC
Switch	4.20 to 5.25 VDC	4.20 to 5.25 VDC

### SOLENOIDS

- Fuel Shutoff Valve
- Coil Resistance = 7 to 8 Ohms
- Injectors
- 0.5 to 1.5 Ohms after subtracting the VOM resistance.

### ECM CONNECTOR

- Retaining Cap Screw Torque = 2 N•m [18 in-lb]

### INJECTOR

- Pigtail Retaining Nut Torque = 1.6 N•m [14 in-lb]

## SENSOR SPECIFICATIONS

### VEHICLE SPEED SENSOR

Torque = 47 N•m [35 ft-lb]

Coil Resistance:

- First Coil = 750 to 1100 Ohms  
Second Coil = 1100 to 1500 Ohms

### THROTTLE PEDAL (IVS, ISS, & TPS)

Idle Validation Circuit Resistance:

- For ON and OFF-IDLE states
- IVS • MAX Closed Circuit Resistance < 10 Ω  
ISS • MAX Closed Circuit Resistance < 125 Ω  
IVS, ISS • MIN Open Circuit Resistance > 100 KΩ

Throttle Position Sensor Coil Resistance:

- Between supply and return wires
- 2000 to 3000 Ohms
- Between supply and signal wires (released pedal)
- 1500 to 3000 Ohms
- Between supply and signal wires (depressed pedal)
- 200 to 1500 Ohms

**NOTE:** Released minus Depressed **MUST** be > 1000 Ohms.

### '91 BOOST PRESSURE SENSOR

Torque (Flange style) = 30 N•m [22 ft-lb]  
Torque (Threaded style) = 14 N•m [10 ft-lb]

Pressure (mmHg)	Pressure [inHg]	Voltage (V)
0	0	0.42 to 0.58
413.66	16.29	1.42 to 1.58
827.47	32.58	2.42 to 2.58
1241.20	48.86	3.42 to 3.58
1654.86	65.15	4.42 to 4.58

### '94 BOOST PRESSURE SENSOR

Torque (Threaded style) = 14 N•m [10 ft-lb]

Pressure (mmHg)	Pressure [inHg]	Voltage (V)
0	0	0.42 to 0.58
646.48	25.45	1.42 to 1.58
1292.88	50.90	2.42 to 2.58
1939.36	76.35	3.42 to 3.58
2585.76	101.80	4.42 to 4.58

### ENGINE POSITION SENSOR

Torque = 20 N•m [15 ft-lb]

Coil Resistance:

- First Coil = 1000 to 2000 Ohms  
Second Coil = 1000 to 2000 Ohms

### AMBIENT AIR PRESSURE SENSOR

Torque (Flange style) = 23 N•m [17 ft-lb]  
Torque (Threaded style) = 14 N•m [10 ft-lb]

Altitude (m)	Altitude [ft]	Voltage (V)
0 (sea level)	0	4.00 to 4.58
915	3000	3.60 to 4.40
1829	6000	3.20 to 4.00
2744	9000	3.00 to 3.80
3659	12000	2.60 to 3.40

Voltage Output =  $\frac{\text{Ambient Pressure [inHg]} \times 4.0 \text{ V}}{30.54 \text{ [inHg]}} + 0.5 \text{ V}$   
(+/- 60m V)

### OIL PRESSURE SENSOR

Torque (Flange style) = 23 N•m [17 ft-lb]  
Torque (Threaded style) = 14 N•m [10 ft-lb]

Pressure (kPa)	Pressure [psi]	Voltage (V)
0	0	0.40 to 0.60
172.37	25	1.40 to 1.60
344.74	50	2.40 to 2.60
517.11	75	3.40 to 3.60
689.48	100	4.40 to 4.60

### ALL TEMPERATURE SENSORS

Torque = 14 N•m [10 ft-lb]

Temperature (C)	Temperature [F]	Resistance (ohms)
0	32	30K to 36K
25	77	9K to 11K
50	122	3K to 4K
75	167	1350 to 1500
100	212	600 to 675

**FAULT CODE INFORMATION**

Engine operating conditions are recorded in the ECM at the time a fault code is first recorded. The following data fields are reported by Compulink™ and Echek™ under the Fault Code menu:

COMPULINK™	ECHEK™	DESCRIPTION
Code	Code	Cummins code in Compulink™ and Echek™
---	PID or SID, FMI	Optional SAE J1587 code in Echek™
Stat	Status	Active or inactive status of fault codes
Spd	MPH	Vehicle speed in MPH or KPH
Th	% Throttle	Percent that throttle pedal was depressed
RPM	RPM	Engine speed
Count	Count	Number of occurrences of a fault code
---	x/y (e.g., 1/3)	Sequence/Total (e.g., first of three fault codes)
Switch position	SW	Switch position at first occurrence of fault

**ENGINE PROTECTION FAULT CODE INFORMATION**

FAULT CODE	FLUID SYSTEM	LIMIT	COMMENTS
143	Low Oil Pressure	Speed Dependent	Power Derate
151	High Coolant Temp	104°C [220°F]	Power Derate, Speed Derate after 115°C [239°F]
155	High Boost Air Temp	84°C [183°F]	Power Derate, Speed Derate after 111°C [231°F]
214	High Oil Temp	124°C [255°F]	Power Derate
235	Low Coolant Level	Installation Dependent	Power Derate
415	Very Low Oil Pressure	Speed Dependent	Speed Derate, Power is already derated with Fault Code 143

**SWITCH POSITIONS\***

1	2	3	4	5	6	7	8	9	10	11	12	13	14	15	16
POSITION	EXPLANATION														
1	Clutch														
2	Service brake														
3	Cruise/Resume														
4	Cruise/Set														
5	Cruise/PTO														
6	Test diagnostic switch														
7	Radiator coolant level high														
8	Radiator coolant level low														
9	Not used														
10	Key switch														
11	Idle validation switch on idle														
12	Remote PTO														
13	Engine brake														
14	Idle validation switch off idle														
15	Idle decrement														
16	Idle increment														
TMP:		Coolant Temperature (Deg. C or F)													
BO:		Boost Pressure (in Hg or mm Hg)													
FUEL:		Percent Fuel (%)													

Note: (\*) If value = 1, Switch Activated when fault was recorded. If value = 0, Switch Not Activated when fault was recorded.

**AUDIT TRAIL**

CODE	EXPLANATION
C1	New calibration
C2	Accelerate/Coast Flag
D1	Vehicle information (make, model ID, year)
E1	Max engine speed without VSS
F1	Low idle adjust feature switch
F2	PTO feature switch
F3	Cruise control feature switch
F4	Progressive shift feature switch
F5	All speed governor feature switch
F6	Idle shut down feature switch
F7	Gear-Down Protection feature switch
F8	Engine protection shutdown switch
I1	Low idle RPM
I2	Idle shutdown time
I3	Idle shut down override
I4	Idle shut down in PTO
M1	Maximum vehicle speed in top gear
M2	Maximum cruise control speed
M3	Maximum vehicle speed in lower gear (light and heavy engine loads)
M4	MPH at maximum progressive shift RPM

**AUDIT TRAIL (Continued)**

CODE	EXPLANATION
P1	Maximum PTO RPM Minimum PTO speed Remote PTO speed
P2	Resume PTO RPM
P3	Set PTO RPM Light load PTO % Fuel
P4	CELECT™ password
P5	New parameter file
S1	Maximum progressive shift RPM
S2	Maximum progressive shift RPM at zero MPH
T1	Overdrive Transmission/Top Transmission Gear Ratio
V1	Tire Revolutions Per Mile Application Type
V2	Rear Axle Ratio, Engine Distance Offset, Engine Time Offset
V3	VSS Anti-Tampering (Fault Code 242) VSS type, VSS(Y/N) MM Feature Switch, MM Mode Selection, MM Distance, MM Time, MM Interval Factor
V4	Number of tailshaft gear teeth Automatic Transmission

To repair CELECT™/PT Pacer™/Pace™ wire harnesses, use Wiring Repair Kit, Part No. 3822926, which is a collection of connectors, seals, wires, test leads, tools and miscellaneous accessories. Distributed by: Cummins Service Products Company, Order Desk 1-800-433-9341.

## CELECT™ FAULT CODE INFORMATION

**LAMPS:** R = Red Y = Yellow EP = Engine Protection Lamp W = With WO = With Out

**ABBREV:** SH = Sensor Harness AH = Actuator Harness OH = OEM Harness

FAULT CODE LAMP	PID(P) SID(S) FMI	REASON	EFFECT
115 R	P190 2	No. engine speed signal detected at pins No. 1 and 15 or 11 and 14 of SH.	Current to injectors turned off. Engine dies.
121 Y	P190 10	No engine speed signal detected at one pair of pins either No. 1 and 15 or 11 and 14 of SH.	None. Possible fueling or timing shift.
122 Y	P102 3	High voltage detected at boost pressure signal pin No. 26 of SH.	None on performance.
123 Y	P102 4	Low voltage detected at boost pressure signal pin No. 26 of SH.	None on performance.
131 R	P091 3	High voltage detected at throttle position signal pin No. 11 of OH.	Severe derate (power and speed). Power to get off road, or limp home if throttle pedal is held down.
132 R	P091 4	Low voltage detected at throttle position signal pin No. 11 of OH.	Severe derate (power and speed). Power to get off road or limp home if throttle pedal is held down.
135 Y	P100 3	High voltage detected at oil pressure signal pin No. 07 of SH.	No engine protection for oil pressure.
141 Y	P100 4	Low voltage detected at oil pressure signal pin No. 07 of SH.	No engine protection for oil pressure.
143 EP	P100 1	Voltage signal at oil pressure signal pin No. 07 of SH indicates oil pressure lower than 55 kPa [8 psi] at idle - 800 rpm; 55 to 173 kPa [8 to 25 psi] at 800 to 1200 rpm; 173 to 208 kPa [25 to 30 psi] at 1200 to 2400 rpm. <b>Note:</b> All N14 engines now use 138 kPa [20 psi] at 1200 RPM instead of 173 kPa [25 psi].	Progressive power derate with increasing time after alert.
144 Y	P110 3	High voltage detected at coolant temperature signal pin No. 17 of SH.	Possible white smoke. Fan on if ECM controlled. No engine protection for coolant temperature.
145 Y	P110 4	Low voltage detected at coolant temperature signal pin No. 17 of SH.	Possible white smoke. Fan on if ECM controlled. No engine protection for coolant temperature.
151 EP	P110 0	Voltage signal at coolant temperature signal pin No. 17 of SH indicates coolant temperature above 104.4°C [220°F].	Progressive power and speed derate with increasing temperature.
153 Y	P105 3	High voltage detected at manifold air temperature signal pin No. 25 of SH.	Fan clutch engaged if ECM controlled. No engine protection for manifold air temperature.
154 Y	P105 4	Low voltage detected at manifold air temperature signal pin No. 25 of SH.	Fan clutch engaged if ECM controlled. No engine protection for manifold air temperature.
155 EP	P105 0	Voltage signal at manifold air temperature signal pin No. 25 of SH indicates manifold air temperature above 82.2°C [180°F].	Progressive power and speed derate with increasing temperature.
212 Y	P175 3	High voltage detected at oil temperature signal pin No. 06 of SH.	No engine protection for oil temperature.
213 Y	P175 4	Low voltage detected at oil temperature signal pin No. 06 of SH.	No engine protection for oil temperature.
214 EP	P175 0	Voltage signal at oil temperature signal pin No. 06 of SH indicates oil temperature above 124.5°C [258°F].	Progressive power derate with increasing temperature.
221 Y	P108 3	High voltage detected at ambient air pressure signal pin No. 27 of SH.	Power derate by 15%.
222 Y	P108 4	Low voltage detected at ambient air pressure signal pin No. 27 of SH.	Power derate by 15%.
234 R	P190 0	Engine speed signal on pins No. 1 and 15 and/or 11 and 14 of SH indicate engine speed greater than 2730 rpm.	Fuel shutoff valve de-energizes. Re-energizes when RPM falls to 2000. Rapid re-start valve opens immediately. Standard valve opens when fuel pressure drops to 103 kPa [15 psi].
235 EP	P111 1	Voltage detected on coolant level low signal pin No. 09 of SH indicates low coolant level on vehicle.	Progressive power derate with increasing time after alert.
241 Y	P084 2	Vehicle speed signal on pins No. 3 and 7 of OH has been lost.	Engine speed limited to "Max. Engine Speed W/O VSS".
242 Y	P084 10	Vehicle speed signal on pins No. 3 and 7 of OH indicates intermittent connection or possible tampering.	Engine speed limited to "Max. Engine Speed W/O VSS".
243 Y	P121 4	Less than 6 volts detected at engine brake relay supply pin No. 18 of AH. Indicates current draw from ECM greater than 2 amps or faulty ECM power supply.	ECM turns off engine brake supply voltage. Engine brakes can not be activated.
245 Y	S033 4	Less than 6 volts detected at fan clutch supply pin No. 07 of AH. Indicates current draw from ECM greater than 2 amps or faulty ECM power supply.	ECM turns off fan clutch supply voltage. Fan will not turn on. Possible engine overheat if ECM controlled fan in use.
254 R	S017 4	Less than 6 volts detected at fuel shutoff solenoid supply pin No. 16 of AH. Indicates current draw from ECM greater than 2 amps or faulty ECM power supply.	ECM turns off fuel shutoff valve supply voltages. Engine dies.
255 Y	S026 3	Externally supplied voltage detected going into ECM fuel shutoff solenoid supply pin No. 16, or fan clutch supply pin No. 07 or engine brake relay supply pin No. 18, all of AH.	None on performance. Fuel shutoff valve or fan clutch or brake enable supply voltage stays on.

FAULT CODE LAMP	PID(P) SID(S) FMI	REASON	EFFECT
311 Y	S001 6	Current detected at No. 1 injector return pin No. 10 of AH when voltage supply at pin No. 01 of AH is off.	Speed derate to 1400 to 1600 RPM. Current to injector is shut off.
312 Y	S005 6	Current detected at No. 5 injector return pin No. 02 of AH when voltage supply at pin No. 11 of AH is off.	Speed derate to 1400 to 1600 RPM. Current to injector is shut off.
313 Y	S003 6	Current detected at No. 3 injector return pin No. 12 of AH when voltage supply at pin No. 03 of AH is off.	Speed derate to 1400 to 1600 RPM. Current to injector is shut off.
314 Y	S006 6	Current detected at No. 6 injector return pin No. 04 of AH when voltage supply at pin No. 13 of AH is off.	Speed derate to 1400 to 1600 RPM. Current to injector is shut off.
315 Y	S002 6	Current detected at No. 2 injector return pin No. 14 of AH when voltage supply at pin No. 05 of AH is off.	Speed derate to 1400 to 1600 RPM. Current to injector is shut off.
321 Y	S004 6	Current detected at No. 4 injector return pin No. 06 of AH when voltage supply at pin No. 15 of AH is off.	Speed derate to 1400 to 1600 RPM. Current to injector is shut off.
322 Y	S001 5	No current detected at No. 1 injector return pin No. 10 of AH when voltage supply at pin No. 01 of AH is on.	Speed derate to 1400 to 1600 RPM. Current to injector is shut off.
323 Y	S005 5	No current detected at No. 5 injector return pin No. 02 of AH when voltage supply at pin No. 11 of AH is on.	Speed derate to 1400 to 1600 RPM. Current to injector is shut off.
324 Y	S003 5	No current detected at No. 3 injector return pin No. 12 of AH when voltage supply at pin No. 03 of AH is on.	Speed derate to 1400 to 1600 RPM. Current to injector is shut off.
325 Y	S006 5	No current detected at No. 6 injector return pin No. 04 of AH when voltage supply at pin No. 13 of AH is on.	Speed derate to 1400 to 1600 RPM. Current to injector is shut off.
331 Y	S002 5	No current detected at No. 2 injector return pin No. 14 of AH when voltage supply at pin No. 05 of AH is on.	Speed derate to 1400 to 1600 RPM. Current to injector is shut off.
332 Y	S004 5	No current detected at No. 4 injector return pin No. 06 of AH when voltage supply at pin No. 15 of AH is on.	Speed derate to 1400 to 1600 RPM. Current to injector is shut off.
333 Y	S254 12	No voltage detected on one or more of the injector supply pins No. 01, 03, 05, 11, 13 or 15 of AH when power is commanded.	Speed derate to 1400 to 1600 RPM.
335 R	S254 12	RAM memory read/write error inside ECM.	Unpredictable - possible no start (no power to either fuel solenoid or injectors).
341 R	S254 12	ROM memory checksum error inside ECM.	Unpredictable - possible no start (no power to either fuel solenoid or injectors).
342 R	S253 12	ECM not calibrated with ESDN or internal EEPROM memory checksum error.	Engine will not start (no power to fuel solenoid).
343 Y	S254 12	Micro-processor communication error inside ECM.	None on performance.
351 Y	S254 12	Injector power supply below specifications inside ECM.	Possible no noticeable effects. Possible reduced performance.
352 Y	S232 4	No outgoing voltage detected at ECM switch supply pin No. 10 of OH ... OR ... low voltage detected at ECM sensor supply pins on SH.	Cruise control/PTO, engine brakes won't work. 431 fault code - Compulink™ shows all switches open ... OR .. derate to no air and simultaneous logging of fault codes, 123, 141, 145, 154, 213, 222 and 422.
411 Y	S249 3	Data transmission error on control data link pins No. 10 and 20 of SH.	Control device will not work properly.
412 Y	S250 3	Data transmission error on vehicle data link pins No. 27 and 08 of OH.	Electronic Service Tool will not work properly.
413 Y	S249 9	Data transmission error on control data link pins No. 10 and 20 of SH.	Control device will not work properly.
414 Y	S250 9	Data transmission error on vehicle data link pins No. 27 and 08 of OH.	Electronic Service Tool will not work properly.
415 EP	P100 1	Voltage signal at oil pressure signal pin No. 07 of SH indicates oil pressure lower than 55 kPa [8 psi] at idle - 800 RPM; 55 to 173 kPa [8 to 25 psi] at 800 to 2400 RPM.	Progressive power and speed derate with increasing time after alert.
422 Y	P111 2	Voltage detected simultaneously on both the coolant level high and low signal pins No. 18 and 9 of SH ... OR ... no voltage detected on either pin.	No engine protection for coolant level.
431 Y	P091 2	Voltage detected simultaneously on both the idle validation off-idle and idle-signal pins No. 09 and 06 of OH ... OR ... no voltage detected on either pin.	None on performance.
432 R	P091 11	Voltage detected at idle validation on-idle signal pin No. 06 or OH when voltage at throttle position signal pin No. 11 of OH indicates pedal is not at idle ... OR ... voltage detected at idle validation off-idle signal pin No. 09 of OH when voltage at throttle position signal pin No. 11 of OH indicates pedal is at rest.	Engine will only idle.
433 Y	P102 2	Voltage signal at boost pressure signal pin No. 26 of SH indicates high boost pressure but other engine characteristics indicate that boost pressure should be low.	None on performance.
434 Y	S251 4	Battery supply voltage at pins No. 20, 21, 22, 23 of AH (relative to return pins No. 09, 25, 27 of AH) fell below 6.2 volts for fraction of a second ... OR ... ECM was not allowed to power down properly (retain battery supply voltage for 3 seconds after voltage on key switch input pin 26 of AH was removed).	Possible no noticeable performance effects. Possibility of engine dying or difficulty in starting engine.